

Contents

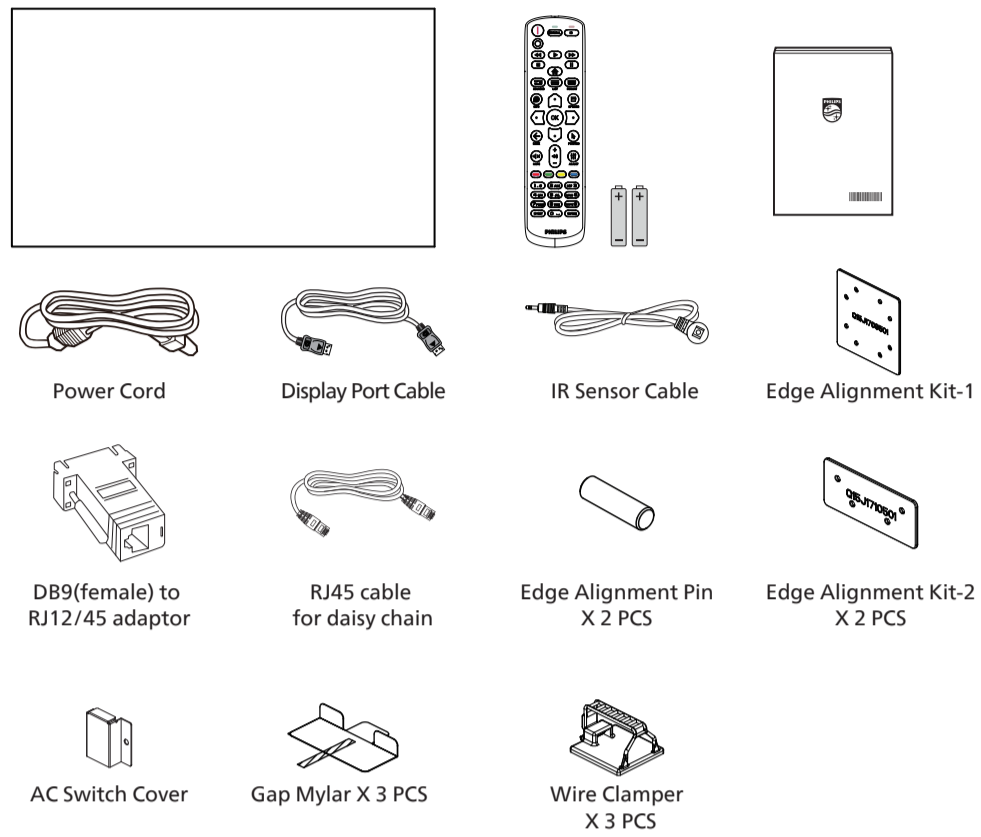

* Differences according to regions.
Display design and accessories may differ from those illustrated above.



1

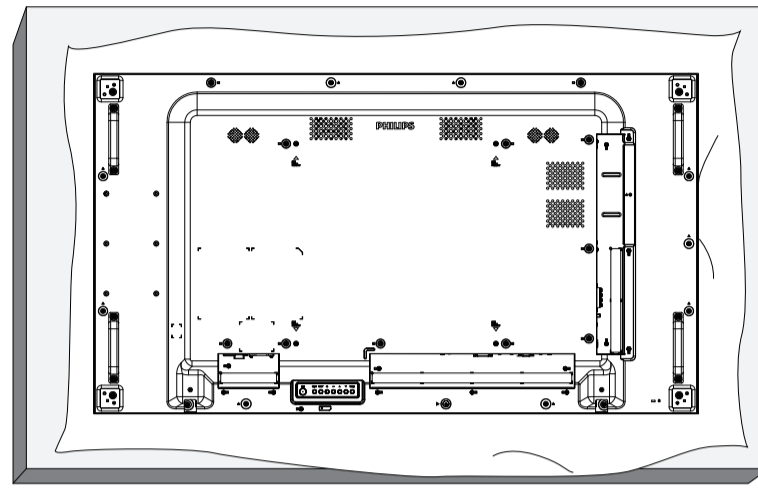

2

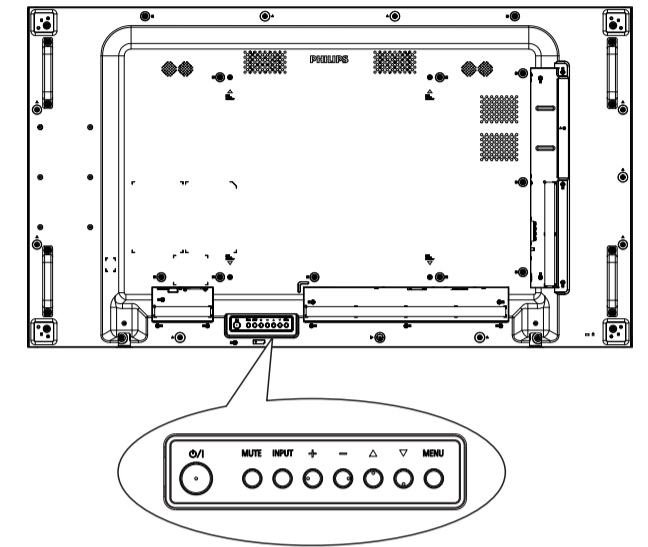

3

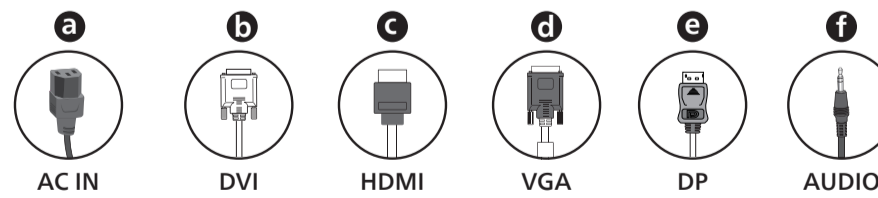
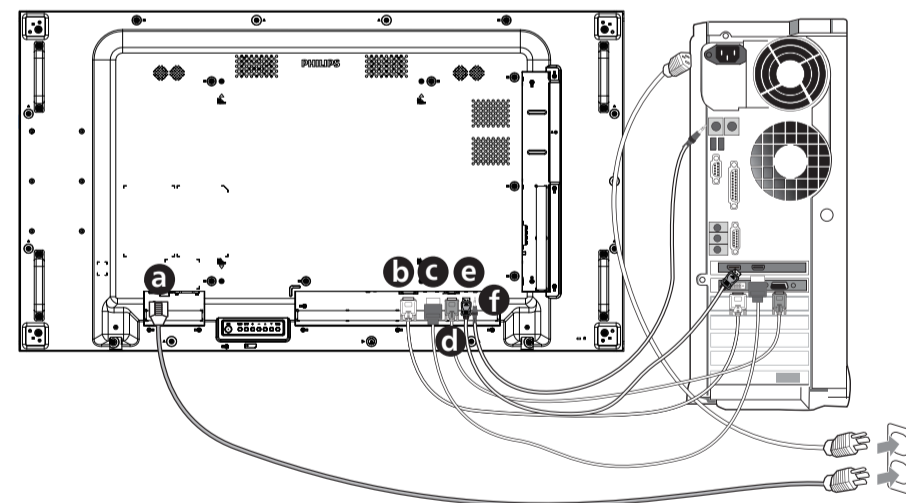
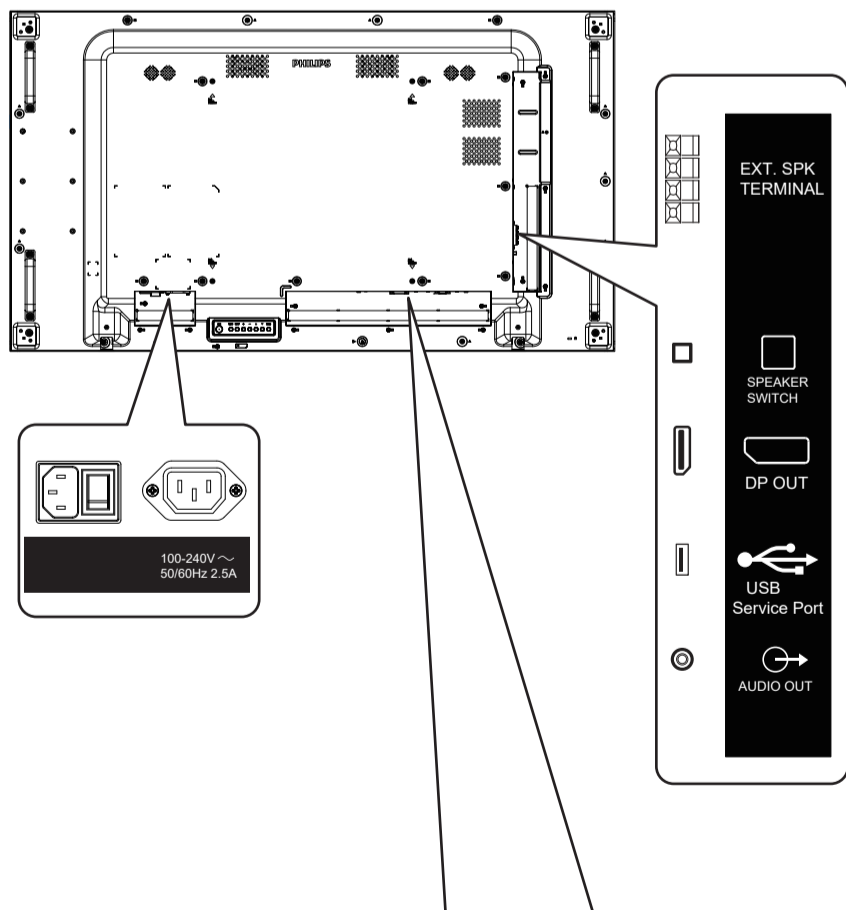

4

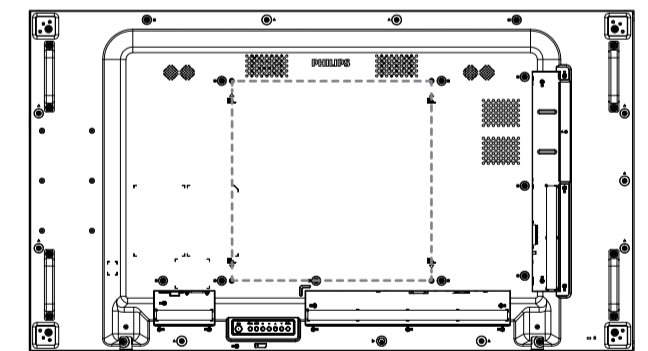

⚙ M6 * (10+X) mm
(X=Thickness of Wall mount BKT)
55BDL8005X/55BDL8007X: 400mm x 400mm

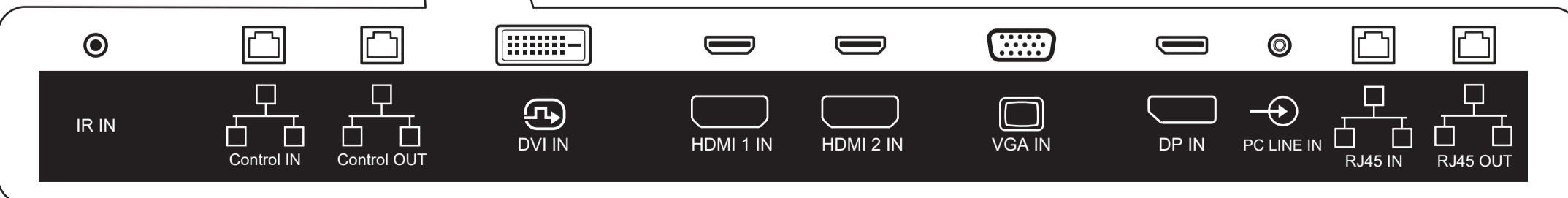

5

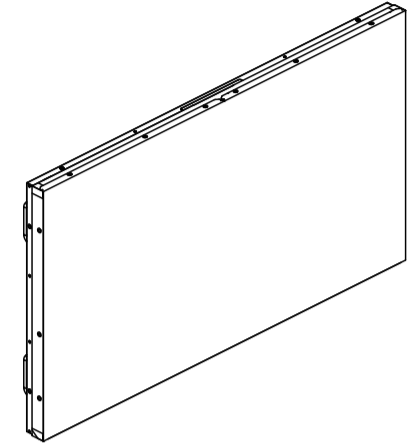
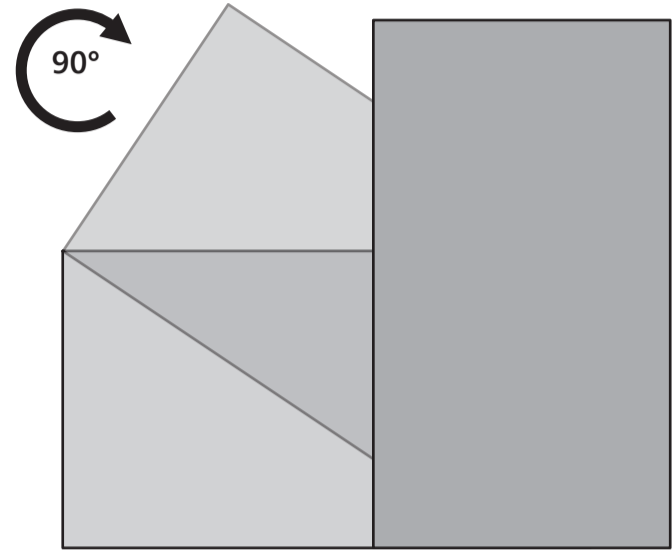

Quick start



For more information, please visit:
www.philips.com/signagesolutions-support



Version: V1.00 2022-02-19

Envision Peripherals Inc.
490 N McCarthy Blvd, Suite #120
Milpitas, CA 95035
USA

2022 © TOP Victory Investments Ltd. All rights reserved.

This product has been manufactured by and is sold under the responsibility of Top Victory Investments Ltd., and Top Victory Investments Ltd. is the warrantor in relation to this product. Philips and the Philips Shield Emblem are registered trademarks of Koninklijke Philips N.V. and are used under license.

Specifications are subject to change without notice.

